

CERTIFICATE

Certified Passive House Component

Component-ID 1239ws04 valid until 31st December 2023

Passive House Institute
Dr. Wolfgang Feist
64283 Darmstadt
Germany

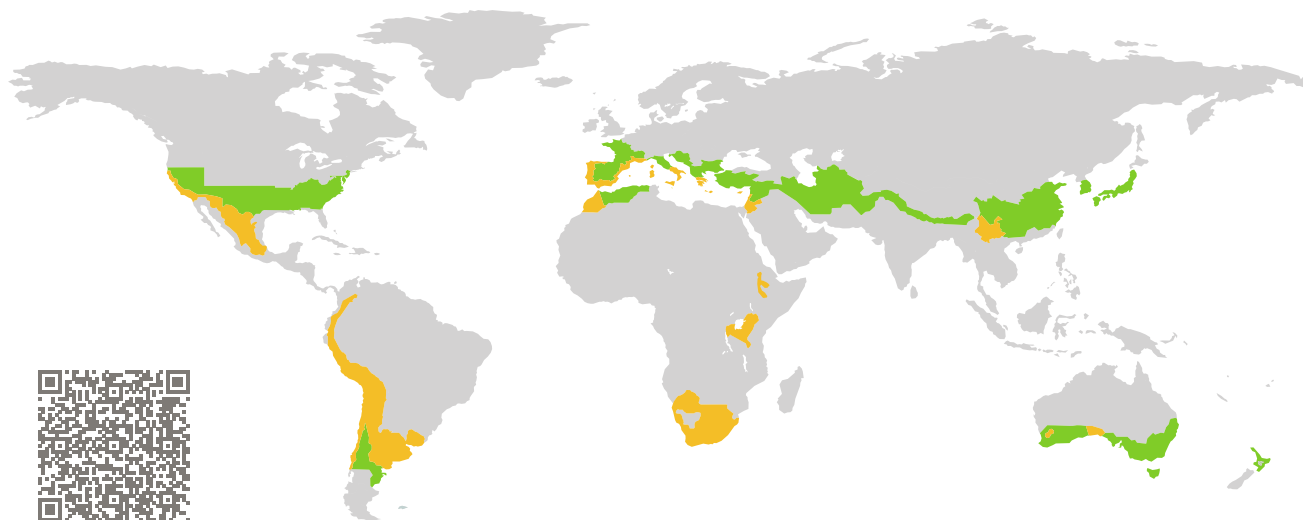

Category: **Window system**
Manufacturer: **GEALAN Fenster Systeme GmbH,
Santa Pola-Alicante,
Spain**
Product name: **Certification S9000**

**This certificate was awarded based on the following
criteria for the warm, temperate climate zone**

Comfort $U_W = 0.99 \leq 1.00 \text{ W}/(\text{m}^2 \cdot \text{K})$
 $U_{W,\text{installed}} \leq 1.05 \text{ W}/(\text{m}^2 \cdot \text{K})$
with $U_g = 0.90 \text{ W}/(\text{m}^2 \cdot \text{K})$

Hygiene $f_{R_{Si=0.25}} \geq 0.65$
Airtightness $Q_{100} = 0.16 \leq 0.25 \text{ m}^3/(\text{h} \cdot \text{m})$

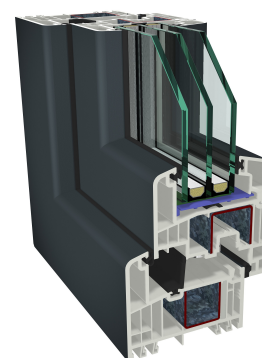

warm, temperate climate

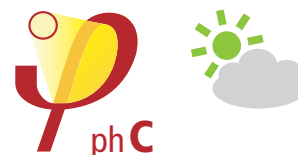

**CERTIFIED
COMPONENT**

Passive House Institute

Passive House
efficiency class

phE

phD

phC

phB

phA

www.passivehouse.com

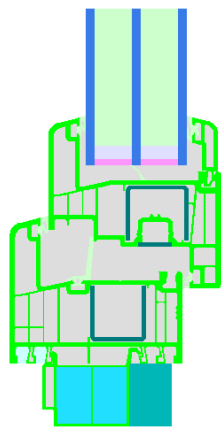

Calculation model

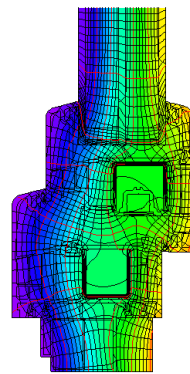

Isothermal

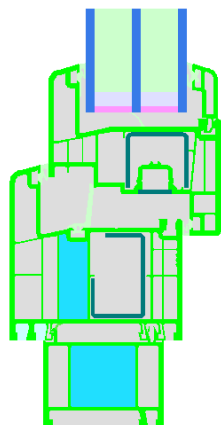
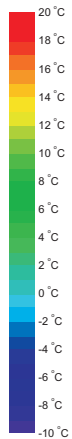

Calculation model

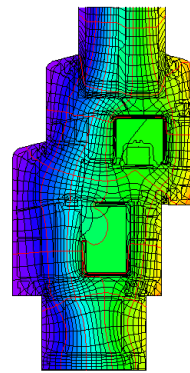

Isothermal

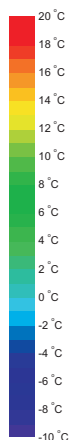

Description

PVC frame with PU foam (IKD®, 0.026 W/(mK)) insulated chamber. The required temperature factor is not achieved at the threshold. The airtightness was approved for a window with flying mullion (1650 mm * 1472 mm). Frame 6002 with reinforcement 6715 and bottom frame extension 7202 IKD, frame 6016 IKD with reinforcement 6716 and frame extension 7299 IKD, sash 6003 with reinforcement 6706, threshold 2596/2576 with 6431 and 6105, mullion 6012 with reinforcement 6711, mullion 6050 with reinforcement 6712. Pane thickness: 48 mm (4/18/4/18/4), rebate depth: 23 mm. Spacer: SWISSPACER Ultimate with polyurethane as secondary seal.

Explanation

The window U-values were calculated for the test window size of 2.46 m × 1.48 m with $U_g = 0.90 \text{ W}/(\text{m}^2 \cdot \text{K})$. If a higher quality glazing is used, the window U-values will improve as follows:

Glazing	$U_g =$	0.90	1.04	0.60	0.52	W/(m ² · K)
		↓	↓	↓	↓	
Window	$U_w =$	0.99	1.09	0.79	0.73	W/(m ² · K)

Transparent building components are classified into efficiency classes depending on the heat losses through the opaque part. The frame U-Values, frame widths, thermal bridges at the glazing edge, and the glazing edge lengths are included in these heat losses. A more detailed report of the calculations performed in the context of certification is available from the manufacturer.

The Passive House Institute has defined international component criteria for seven climate zones. In principle, components which have been certified for climate zones with higher requirements may also be used in climates with less stringent requirements. In a particular climate zone it may make sense to use a component of a higher thermal quality which has been certified for a climate zone with more stringent requirements.

Further information relating to certification can be found on www.passivehouse.com and passipedia.org.

Frame values			Frame width b_f mm	U -value frame U_f W/(m ² · K)	Ψ -glazing edge Ψ_g W/(m · K)	Temp. Factor $f_{RSI=0.25}$ [-]
Mullion Fixed	(0M1)		92	1.05	0.023	0.71
Transom Fixed	(0T1)		140	1.05	0.023	0.71
Mullion 1 casement	(1M1)		140	1.07	0.023	0.69
Transom 1 casement	(1T1)		92	1.07	0.023	0.69
Mullion 2 casements	(2M1)		188	1.07	0.024	0.68
Transom 2 casements	(2T1)		188	1.07	0.024	0.68
Bottom Fixed	(FB1)		100	0.91	0.022	0.71
Bottom Fixed	(FB2)		125	1.01	0.022	0.72
Top Fixed	(FH1)		70	0.96	0.023	0.72
Top Fixed	(FH2)		84	0.89	0.022	0.72
Lateral Fixed	(FJ1)		70	0.96	0.023	0.72
Lateral Fixed	(FJ2)		84	0.89	0.022	0.72
Flying Mullion	(FM1)		170	1.08	0.022	0.65
Bottom	(OB1)		148	0.97	0.023	0.73
Bottom	(OB2)		174	1.04	0.024	0.73
Top	(OH1)		118	1.02	0.023	0.73
Top	(OH2)		132	0.98	0.024	0.73
Lateral	(OJ1)		118	1.02	0.023	0.73
Lateral	(OJ2)		132	0.98	0.024	0.73

Spacer: SWISSPACER Ultimate

Secondary seal: Polysulfid

Frame values	Frame width b_f mm	U -value frame U_f W/(m ² · K)	Ψ -glazing edge Ψ_g W/(m · K)	Temp. Factor $f_{Rsi=0.25}$ [-]
Threshold (OT2) 	92	1.71	0.023	0.63
Spacer: SWISSPACER Ultimate		Secondary seal: Polysulfid		

 Mullion Fixed

$b_f = 92 \text{ mm}$
 $U_f = 1.05 \text{ W/(m}^2 \cdot \text{K)}$
 $\Psi_g = 0.023 \text{ W/(m} \cdot \text{K)}$
 $f_{Rsi} = 0.71$



 Transom Fixed

$b_f = 140 \text{ mm}$
 $U_f = 1.05 \text{ W/(m}^2 \cdot \text{K)}$
 $\Psi_g = 0.023 \text{ W/(m} \cdot \text{K)}$
 $f_{Rsi} = 0.71$



 Mullion 1 casement

$b_f = 140 \text{ mm}$
 $U_f = 1.07 \text{ W/(m}^2 \cdot \text{K)}$
 $\Psi_g = 0.023 \text{ W/(m} \cdot \text{K)}$
 $f_{Rsi} = 0.69$



 Transom 1 casement

$b_f = 92 \text{ mm}$
 $U_f = 1.07 \text{ W/(m}^2 \cdot \text{K)}$
 $\Psi_g = 0.023 \text{ W/(m} \cdot \text{K)}$
 $f_{Rsi} = 0.69$





Mullion 2 casements

$$b_f = 188 \text{ mm}$$

$$U_f = 1.07 \text{ W}/(\text{m}^2 \cdot \text{K})$$

$$\Psi_g = 0.024 \text{ W}/(\text{m} \cdot \text{K})$$

$$f_{Rsi} = 0.68$$

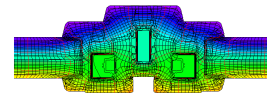

Transom 2 casements

$$b_f = 188 \text{ mm}$$

$$U_f = 1.07 \text{ W}/(\text{m}^2 \cdot \text{K})$$

$$\Psi_g = 0.024 \text{ W}/(\text{m} \cdot \text{K})$$

$$f_{Rsi} = 0.68$$

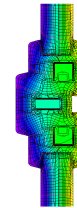

Bottom Fixed

$$b_f = 100 \text{ mm}$$

$$U_f = 0.91 \text{ W}/(\text{m}^2 \cdot \text{K})$$

$$\Psi_g = 0.022 \text{ W}/(\text{m} \cdot \text{K})$$

$$f_{Rsi} = 0.71$$

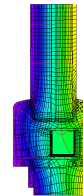
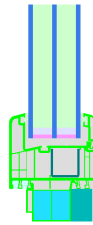

Bottom Fixed

$$b_f = 125 \text{ mm}$$

$$U_f = 1.01 \text{ W}/(\text{m}^2 \cdot \text{K})$$

$$\Psi_g = 0.022 \text{ W}/(\text{m} \cdot \text{K})$$

$$f_{Rsi} = 0.72$$

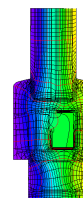
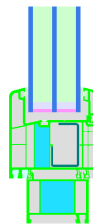

Top Fixed

$$b_f = 70 \text{ mm}$$

$$U_f = 0.96 \text{ W}/(\text{m}^2 \cdot \text{K})$$

$$\Psi_g = 0.023 \text{ W}/(\text{m} \cdot \text{K})$$

$$f_{Rsi} = 0.72$$

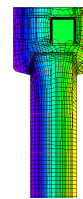
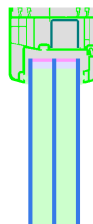



Top Fixed

$$b_f = 84 \text{ mm}$$

$$U_f = 0.89 \text{ W}/(\text{m}^2 \cdot \text{K})$$

$$\Psi_g = 0.022 \text{ W}/(\text{m} \cdot \text{K})$$

$$f_{Rsi} = 0.72$$

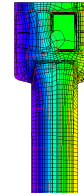
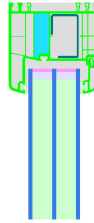

Lateral Fixed

$$b_f = 70 \text{ mm}$$

$$U_f = 0.96 \text{ W}/(\text{m}^2 \cdot \text{K})$$

$$\Psi_g = 0.023 \text{ W}/(\text{m} \cdot \text{K})$$

$$f_{Rsi} = 0.72$$

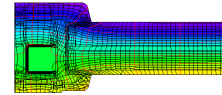
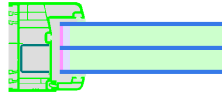

Lateral Fixed

$$b_f = 84 \text{ mm}$$

$$U_f = 0.89 \text{ W}/(\text{m}^2 \cdot \text{K})$$

$$\Psi_g = 0.022 \text{ W}/(\text{m} \cdot \text{K})$$

$$f_{Rsi} = 0.72$$

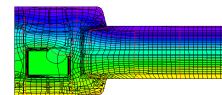
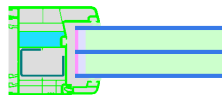

Flying Mullion

$$b_f = 170 \text{ mm}$$

$$U_f = 1.08 \text{ W}/(\text{m}^2 \cdot \text{K})$$

$$\Psi_g = 0.022 \text{ W}/(\text{m} \cdot \text{K})$$

$$f_{Rsi} = 0.65$$

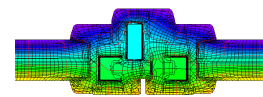

Bottom

$$b_f = 148 \text{ mm}$$

$$U_f = 0.97 \text{ W}/(\text{m}^2 \cdot \text{K})$$

$$\Psi_g = 0.023 \text{ W}/(\text{m} \cdot \text{K})$$

$$f_{Rsi} = 0.73$$

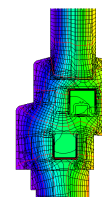
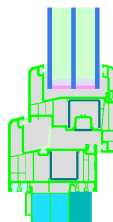



Bottom

$$b_f = 174 \text{ mm}$$

$$U_f = 1.04 \text{ W}/(\text{m}^2 \cdot \text{K})$$

$$\Psi_g = 0.024 \text{ W}/(\text{m} \cdot \text{K})$$

$$f_{Rsi} = 0.73$$

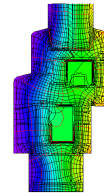

Top

$$b_f = 118 \text{ mm}$$

$$U_f = 1.02 \text{ W}/(\text{m}^2 \cdot \text{K})$$

$$\Psi_g = 0.023 \text{ W}/(\text{m} \cdot \text{K})$$

$$f_{Rsi} = 0.73$$

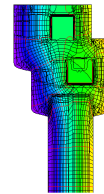
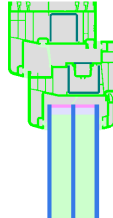

Top

$$b_f = 132 \text{ mm}$$

$$U_f = 0.98 \text{ W}/(\text{m}^2 \cdot \text{K})$$

$$\Psi_g = 0.024 \text{ W}/(\text{m} \cdot \text{K})$$

$$f_{Rsi} = 0.73$$

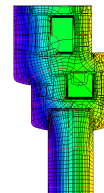
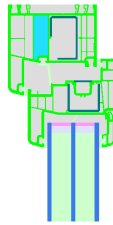

Lateral

$$b_f = 118 \text{ mm}$$

$$U_f = 1.02 \text{ W}/(\text{m}^2 \cdot \text{K})$$

$$\Psi_g = 0.023 \text{ W}/(\text{m} \cdot \text{K})$$

$$f_{Rsi} = 0.73$$

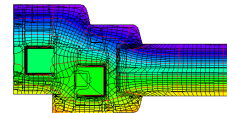
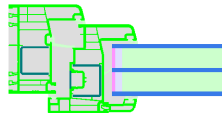

Lateral

$$b_f = 132 \text{ mm}$$

$$U_f = 0.98 \text{ W}/(\text{m}^2 \cdot \text{K})$$

$$\Psi_g = 0.024 \text{ W}/(\text{m} \cdot \text{K})$$

$$f_{Rsi} = 0.73$$

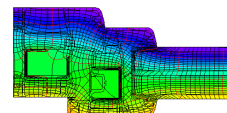
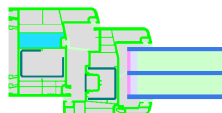



Threshold

$$b_f = 92 \text{ mm}$$
$$U_f = 1.71 \text{ W}/(\text{m}^2 \cdot \text{K})$$
$$\Psi_g = 0.023 \text{ W}/(\text{m} \cdot \text{K})$$
$$f_{Rsi} = 0.63$$

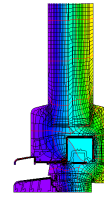
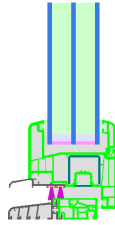

Validated installations

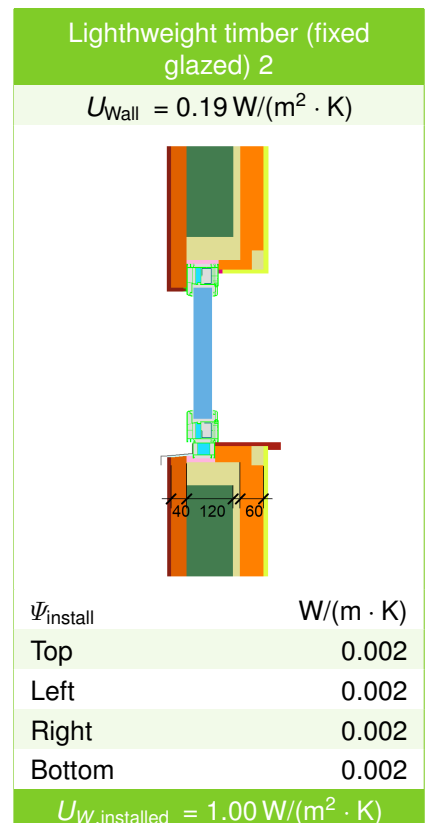
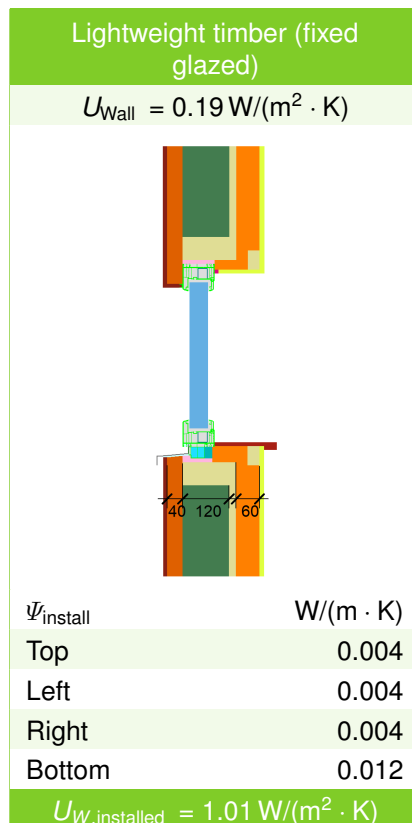
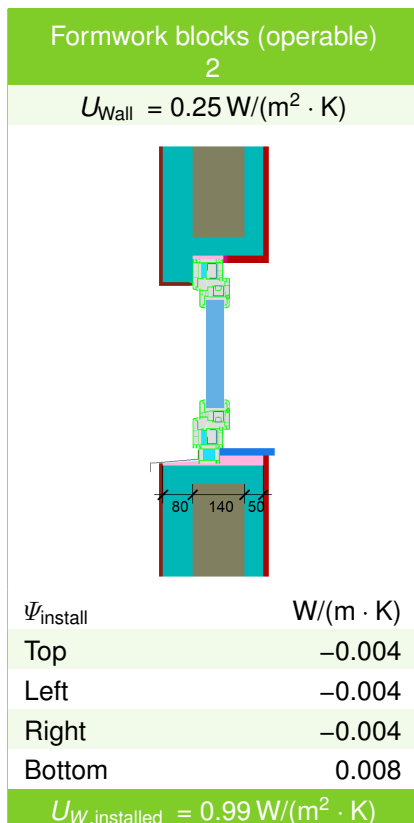
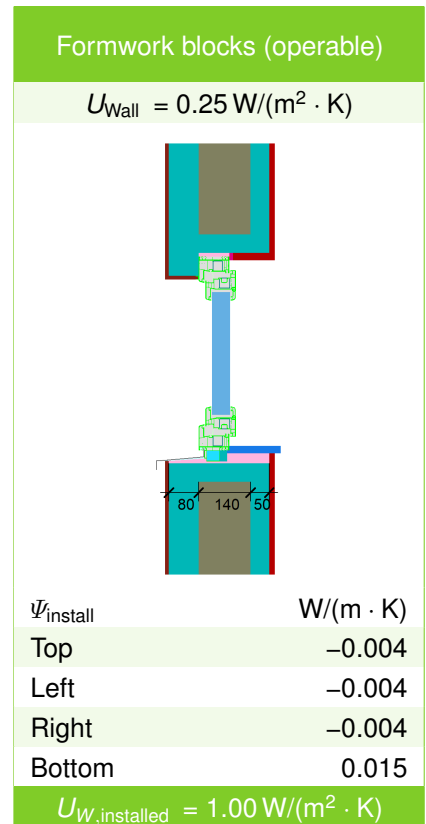
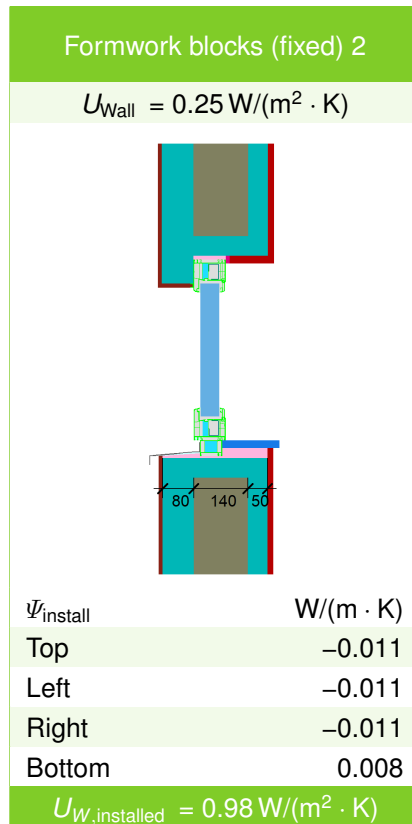
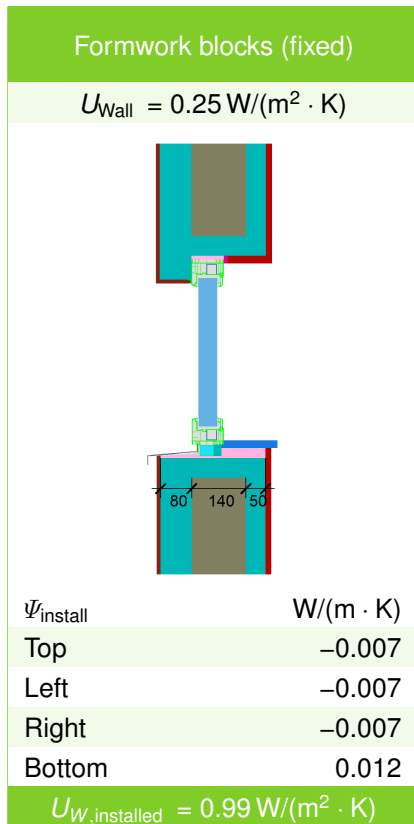

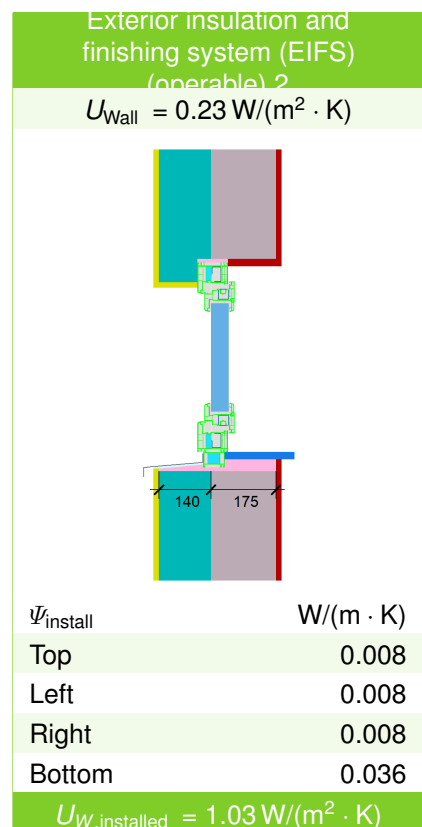
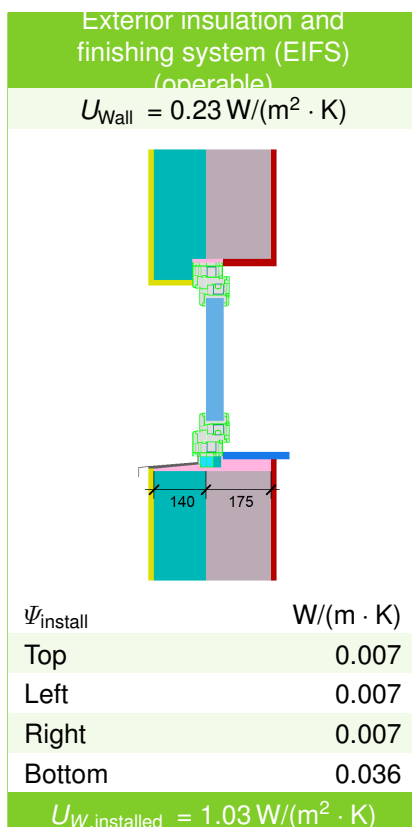
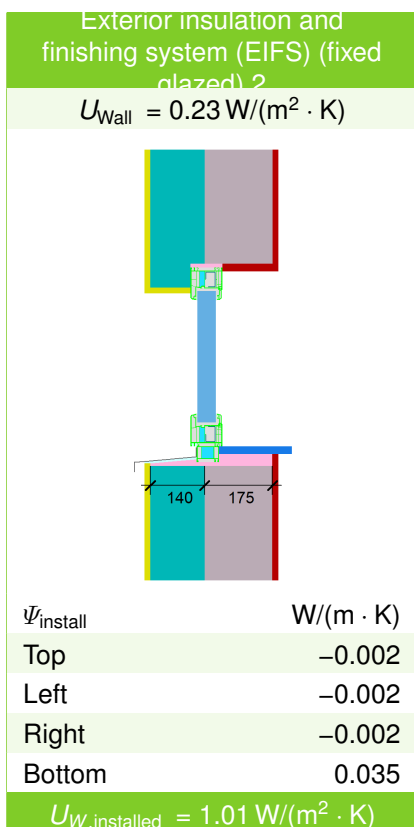
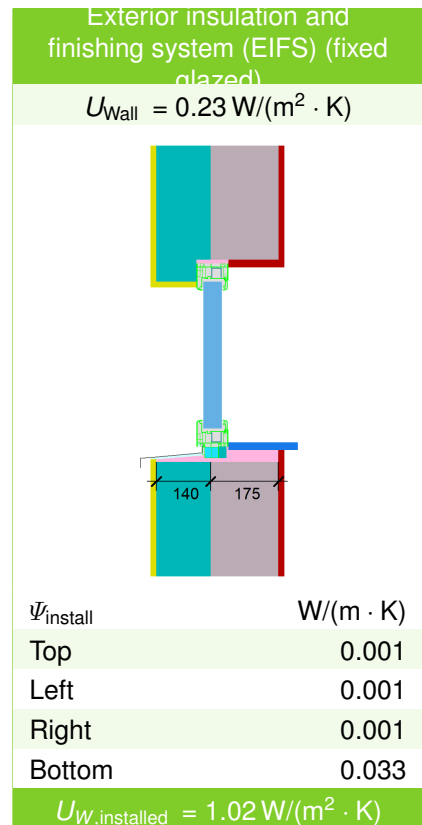
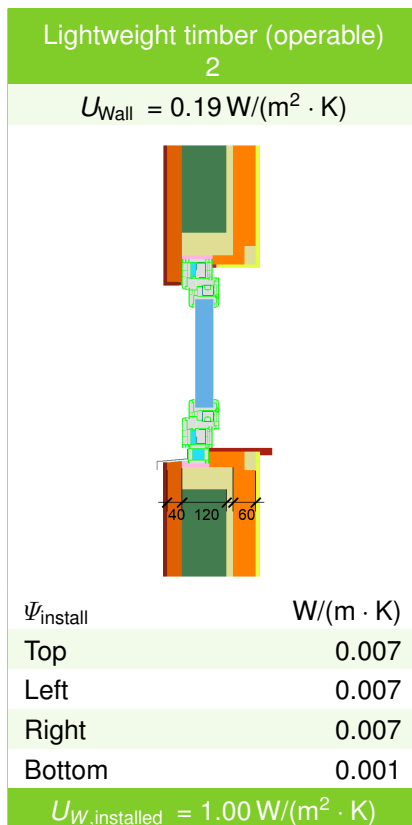
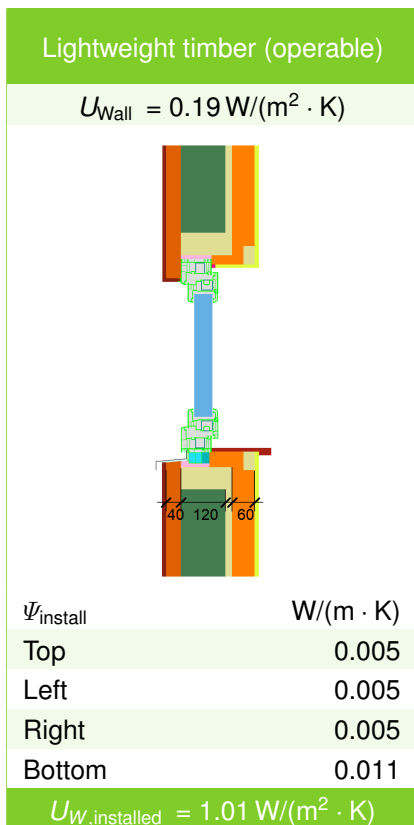

Exterior insulation and finishing s (EIFS)
threshold (operable)

$$U_1 = 0.23 \quad U_2 = 0.22 \quad [\text{W}/(\text{m}^2 \cdot \text{K})]$$

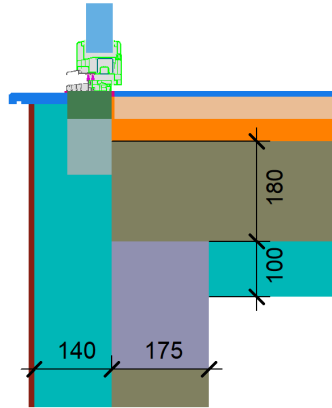

$$\Psi_{\text{install}} = -0.01 \text{ W}/(\text{m} \cdot \text{K})$$

